

∅ 250 [9.84]

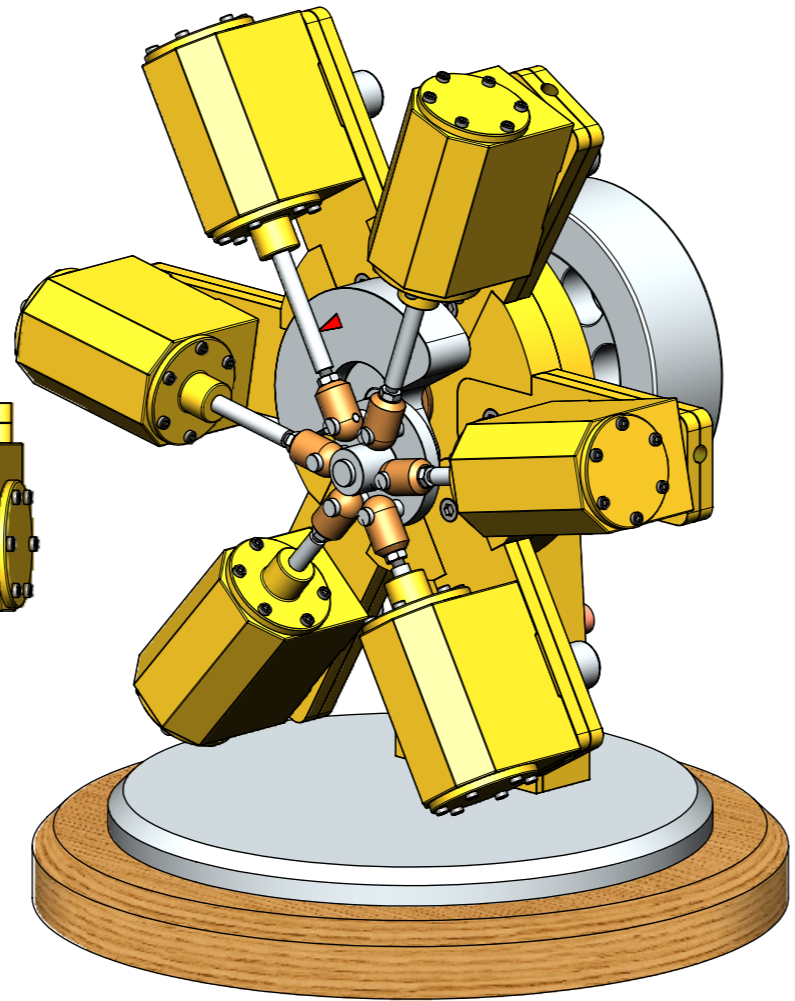

MATERIAL ABBREVIATIONS:
 ALU = ALUMINIUM
 HALU= HARD ALUMINIUM
 BRS = BRASS
 BRZ = BRONZE OR GUNMETAL (BRZ/GM)
 CI = CAST IRON
 CU = COPPER
 GRA = GRAPHITE
 MS = MILD STEEL/BRIGHT MILD STEEL
 SS = SILVER STEEL OR STAINLESS STEEL
 SPS = SPRING STEEL
 PEEK= POLYETHER ETHER KETONE
 SYN = SYNTHETIC MATERIAL SUCH AS VETON, NYLON, TEFLON OR RUBBER
 IN GENERAL SYNTHETIC MATERIALS SHOULD BE ABLE TO WITHSTAND THE HEAT AND PRESSURE(S) APPLIED TO THEM.
 nnn/nnn MEANS THAT EITHER MATERIAL CAN BE USED

OTHER ABBREVIATIONS
 DP = DEEP
 DAA= DRILL AFTER ASSEMBLY
 D&TAA= DRILL AND TAP AFTER ASSEMBLY
 CF = CLOSE FIT (SIZE FOR SIZE)
 PF = PRESS FIT
 PFAA= PRESS FIT AFTER ASSEMBLY
 PCD = PITCH CIRCLE DIAMETER
 RM = REAM
 HEX = HEXAGON, 6SIDED
 CP = COMPRESSED
 KNL = KNURLED
 CSK = COUNTERSINK
 PL = PLACES
 DWL= DOWEL
 SPF= SPOTFACE
 (T)HESOP=(TAPPED)HOLES EQUALLY SPACED ON PCD
 (T)HESOC=(TAPPED)HOLES EQUALLY SPACED ON CIRCUMFERENCE
 [SA-xxx]= SUB ASSEMBLY-xxx

QTY.	PART NUMBER
1	6CODASE-1-01-COLUMN BASE
1	6CODASE-1-02-ENGINE COLUMN
1	6CODASE-1-03-COLUMN PORT DISC
6	6CODASE-1-04-CYLINDER PORT BLOCK
1	6CODASE-2-01-CRANKSHAFT+CRANK DISC
1	6CODASE-2-02-FLYWHEEL
6	6CODASE-2-03-CYLINDER
6	6CODASE-2-04-PISTON
1	6CODASE-2-05-CRANKPIN DISC
6	6CODASE-2-06-CYLINDER PIVOT SPRING
6	6CODASE-2-07-SPRING CAP
72	6CODASE-M3x12 A-K CYL HEAD SCREW
6	6CODASE-M4 NUT
9	6CODASE-M4x12 A-K C-SINK SCREW
1	6CODASE-M5x10 A-K GRUB SCREW
6	6CODASE-M5x28 A-K C-SINK SCREW
6	6CODASE-M6 WASHER
2	6CODASE-M6x26 A-K C-SINK SCREW
3	6CODASE-M6x34 A-K C-SINK SCREW
2	6CODASE-M6x40 A-K C-SINK SCREW
1	6CODASE-M12 NUT-BRASS

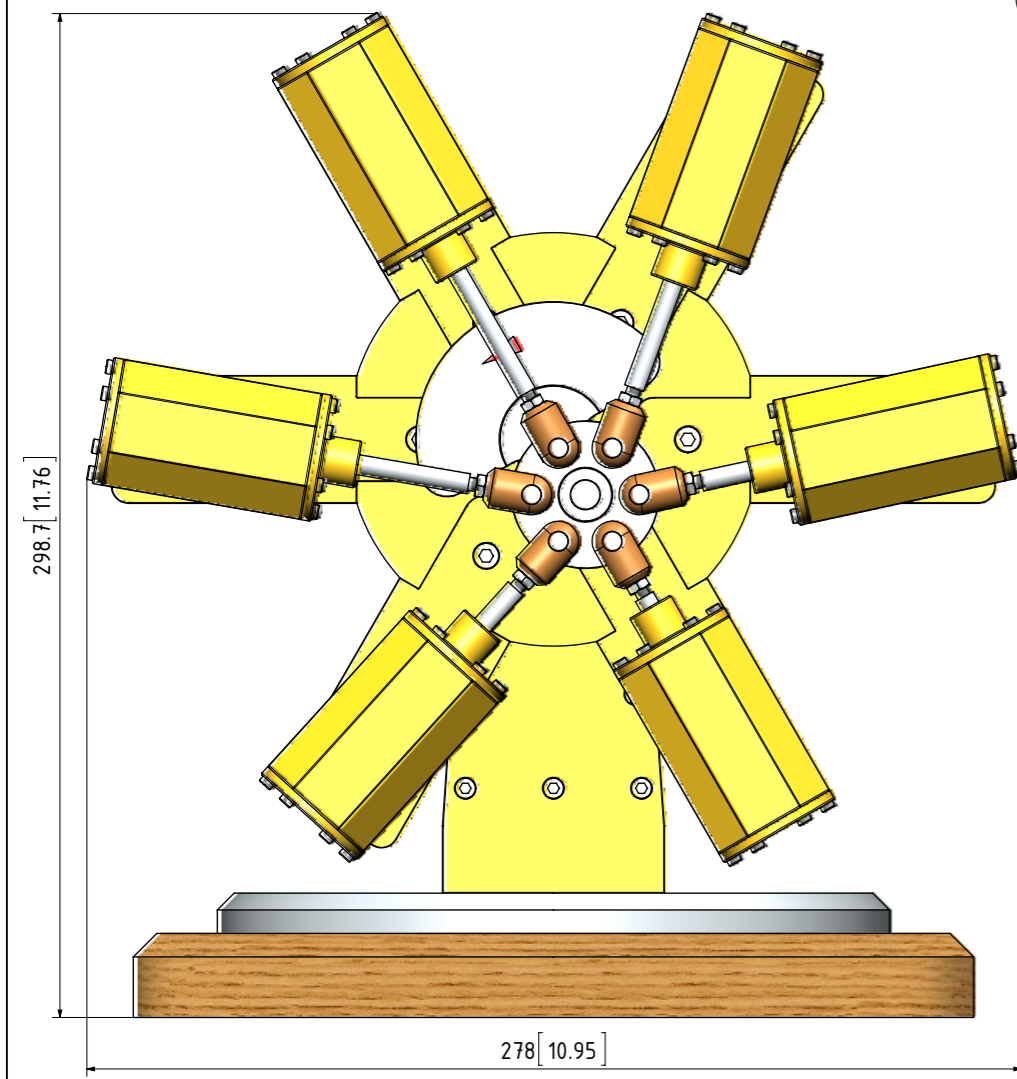

298.7 [11.76]

278 [10.95]

NOTES:
 0. ALL DRAWINGS ARE IN METRIC MEASUREMENTS
 1. ALL ENGINEERING PRACTICES SHALL BE APPLIED WITH REGARDS TO HOLE AND SHAFT TOLERANCES.
 2. WHERE SCREWS OR BOLTS ARE USED THE CLEARANCE HOLES SHALL BE APPROXIMATELY 5% TO 8% LARGER THAN THE MATCHING TAPPED HOLE.
 3. PREFERABLY ALL TAPPED HOLES AND MATCHING SCREWS AND/OR BOLTS TO BE METRIC FINE (MF)
 4. MATERIALS SPECIFIED ON THE DRAWINGS ARE INDICATIVE ONLY. THE BUILDER CAN MAKE HIS/HER OWN MATERIAL CHOICE.
 5. ALL CONNECTIONS/JOINTS WHICH HAVE STEAM PRESSURE APPLIED TO IT SHALL BE SILVER/HARD SOLDERED.
 6. COMPRESSION SPRINGS ARE DRAWN IN COMPRESSED STATE (CP), UNCOMPRESSED STATE IS APPROX 40% TO 60% LONGER THEN COMPRESSED STATE.
 7. WHERE PREFERRED SCREW OR RIVETED CONNECTIONS CAN BE OMITTED AND PARTS CAN BE BONDED TOGETHER BY USING EITHER HIGH STRENGTH GLUE, EPOXY RESIN, OR SOLDER.
 8. PARTS WHICH ARE DIRECTLY EXPOSED TO STEAM AND/OR WATER SHOULD BE CONSTRUCTED USING NON-FERROUS OR NON CORROSIVE MATERIAL SUCH AS BRASS, BRONZE, GUNMETAL, STAINLESS STEEL, COPPER OR MONEL.
 9. THE ORDER IN WHICH THE PARTS/COMPONENTS ARE MANUFACTURED AND THE MODEL IS ASSEMBLED IS ENTIRELY LEFT TO THE BUILDER/MODEL MAKER.
 10. A COLOUR SCHEME FOR THIS PROJECT IS ENTIRELY LEFT UP TO THE MODEL MAKER.
 11. THE MANNER IN WHICH THE PARTS/COMPONENTS ARE MANUFACTURED IS ENTIRELY LEFT UP TO THE BUILDER.
 12. USE LOCTITE, ON SCREW OR PRESS FIT CONNECTIONS OR SURFACES, WERE DEEMED NECESSARY TO PREVENT PARTS FROM LOOSENING.
 13. WASHERS AND/OR SPRINGWASHERS SHALL BE USED WHERE DEEMED NECESSARY.
 14. N/A
 XX. ERRORS AND/OR OMISSIONS MAY OCCUR IN THE DRAWINGS, DO NOT HESITATE TO CONTACT ME SO THAT THE ERRORS/OMISSIONS CAN BE RECTIFIED.

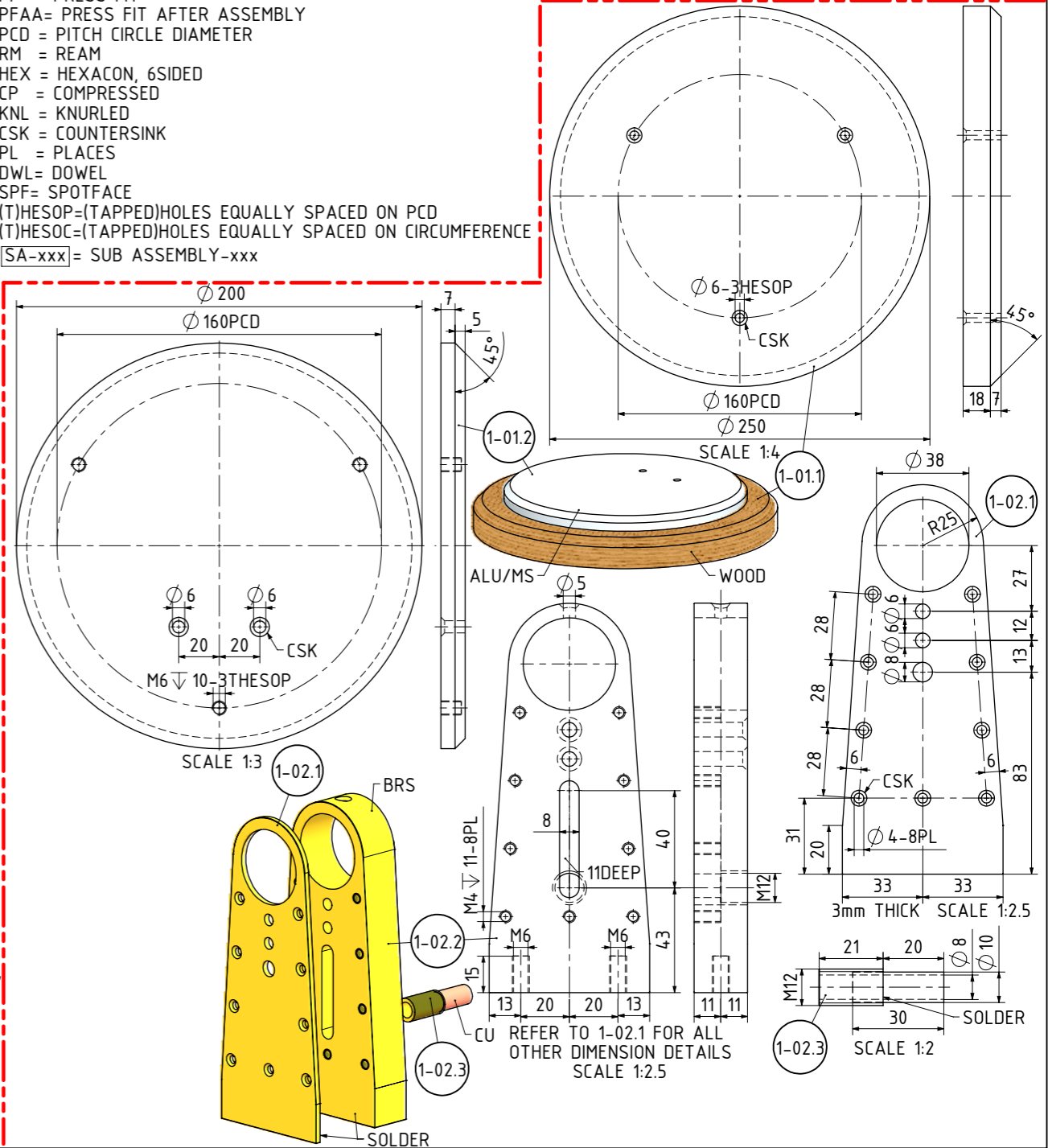

NOTES: THIS DESIGN IS LOOSELY BASED ON A SET OF DRAWINGS WHICH WERE GIVEN TO ME. THE ORIGINAL DRAWINGS AND ARTICLE WERE PUBLISHED IN A UNSPECIFIED MAGAZINE (PAGES 26 TO 41) UNDER THE TITLE "HULA-HULA ENGINE" BY PHILIP DUCLOS.

TITLE
A SIMPLE 6 CYLINDER OSCILLATING STEAM ENGINE

DRAWING CONTENTS
GENERAL ARRANGEMENT, BOM, NOTES, PARTS AND ASSEMBLIES

PROJECT No 09A-24-00
 JDW DRAUGHTING SERVICES
 J.A.M. DE WAAL, 12 BRIGHTWELL STREET PAPA KURA 2110.
 NEW ZEALAND. PHONE: 0064 09 2988815. MOB: 0211791000
 E-MAIL: dewaal@xtra.co.nz.

PROJECTION
JDWDS
 DATE AUGUST 2018
 SHEET: 01 OF 02

MODEL SCALE: 1:1
 DWG SCALE: 1:1 @A3 OR AS SHOWN
 Copyright © J.A.M. DE WAAL PAPA KURA NZ
A3 No: 09A-24-00-SHT01

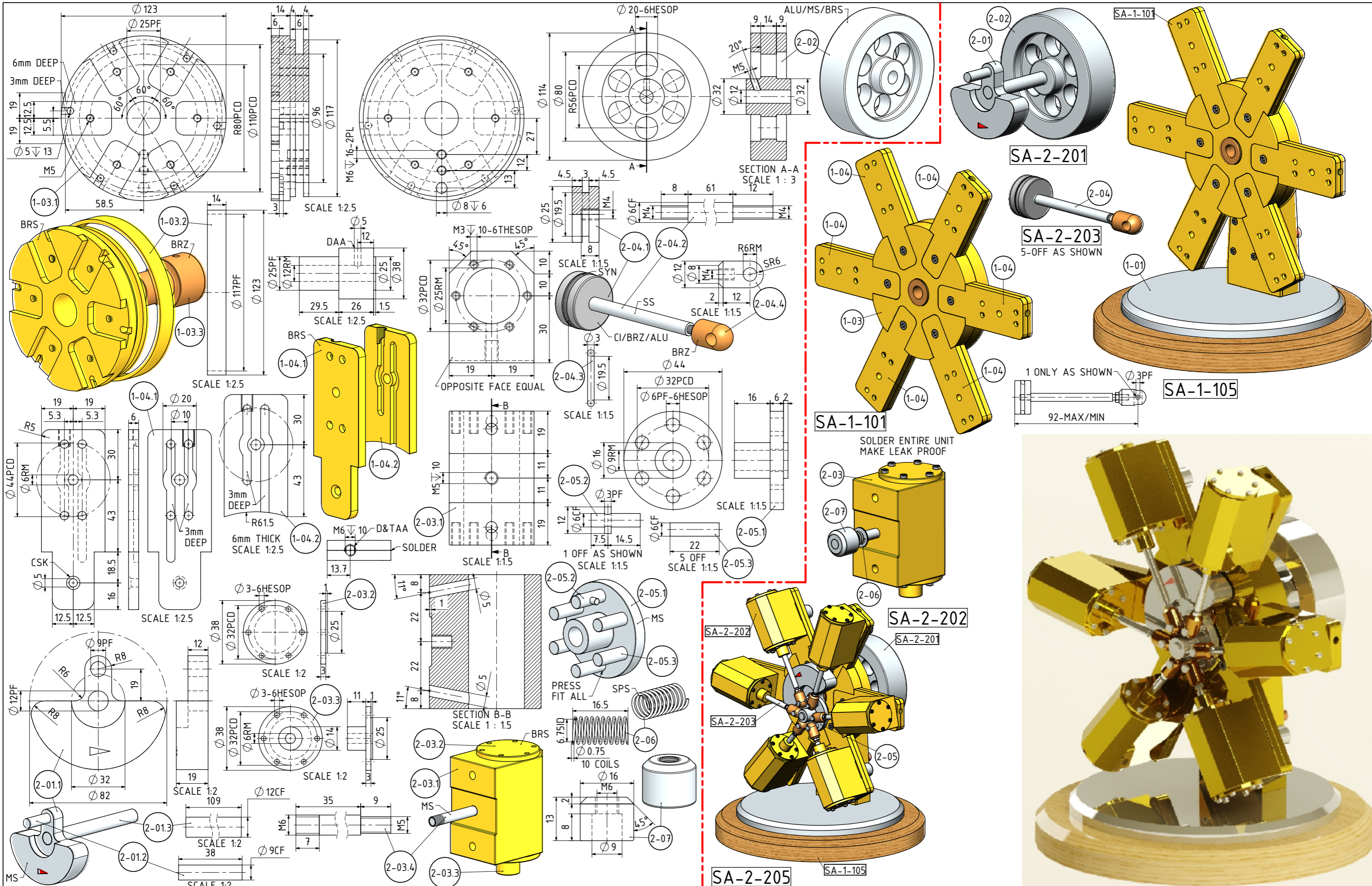

NOTES: THIS DESIGN IS LOOSELY BASED ON A SET OF DRAWINGS WHICH WERE GIVEN TO ME. THE ORIGINAL DRAWINGS AND ARTICLE WERE PUBLISHED IN A UNSPECIFIED MAGAZINE (PAGES 26 TO 41) UNDER THE TITLE "HULA-HULA ENGINE" BY PHILIP DUCLOS.

TITLE
A SIMPLE 6 CYLINDER OSCILLATING STEAM ENGINE

DRAWING CONTENTS
PARTS AND ASSEMBLIES

PROJECT No 09A-24-00
 JDW DRAUGHTING SERVICES
 J.A.M. DE WAAL, 12 BRIGHTWELL STREET PAPAURA 2110.
 NEW ZEALAND. PHONE: 0064 09 2988815. MOB: 0211791000
 E-MAIL: dewaal@xtra.co.nz.

PROJECTION
JDWDS
 DATE AUGUST 2018
 SHEET: 02 OF 02
 MODEL SCALE: 1:1
 DWG SCALE: 1:1 @A3 OR AS SHOWN
 Copyright © J.A.M. DE WAAL PAPAURA NZ
A3 No: 09A-24-00-SHT02